

# 22" industrial touchscreen display with Projected Capacitive (PCAP) technology

Designed for industrial use and meets IP65 requirements. ML 505 is ideal solution for dusty or wet conditions. PCAP touchscreen ensures intuitive and smooth user experience.

## HIGHLIGHTS

- Stainless steel housing, meets food industry requirements. • Industrial touchscreen display with Projected Capacitive technology
- Flexible mounting with special holder or via VESA mounting
- Powerful Intel® NUC PC module with Intel® Core™ i3 and i5 Processors
- Low power consumption less (than 60 W)
- Different I/O connectors for special additional equipment (e.g. weighing devices, sensors, printers etc.)



## OPTIONAL FEATURES

- **Different touchscreen sizes.** Available screen sizes 19", 22", 32" and 43"
- **Custom I/O connectors.** Possible to order special IP67 connectors (RS232, RJ45, USB-A or others)
- **Connectivity.** Optional wireless network connectivity options (WiFi, LTE) with vandal proof external antenna to provide kiosk connectivity in all possible locations.
- **Computer.** Powerful Intel® NUC PC module with Intel® Core™ i3 and i5 Processors, Elo Backpack Android Compute Engine or similar
- **Security.** The housing is suited for unattended self-service. Housing can be anchored to wall, table or with special VESA mounting.
- **Optional devices.** This model can be equipped with RFID, 2D/3D, scanner or other devices at request.

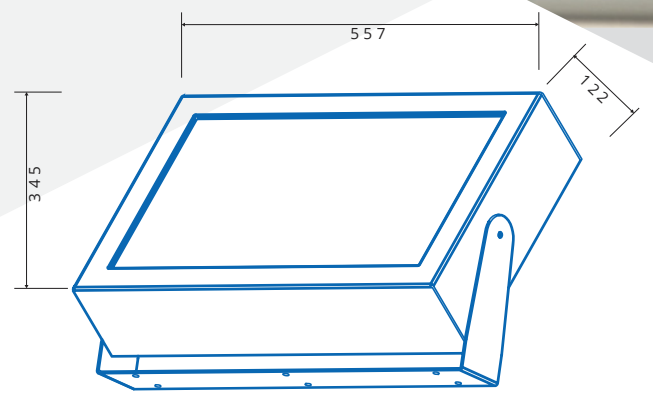

ML 505/22" dimensions

## ABOUT US

We are in kiosk production from 1999. Our production and product development process is certified to meet industry standards requirements. We are proud to design our kiosks in-house keeping in mind both aesthetic and functionality.

